

CashPlus Flip Lid

CashPlus is a generic portfolio of cash drawers, and has been selected from over 10,000 designs to reflect the unparalleled quality and flexibility that is customary to all Cash Bases products. Each drawer offers unique features, configurable inserts and variable dimensions, suitable for any retail environment, anywhere in the world.

DESCRIPTION

Industry acclaimed as being 'best of breed', the Cash Bases Flip Lid is the automatic choice of food retailers.

FEATURES

- Robust steel construction
- Drawer status micro switch

OPTIONS

- Wide range of inserts - plastic or steel
- Floppy note dividers to maximize note storage
- Fixed or removable coin cups
- Coin cups suitable for weigh counting
- Anti grab flap over note compartment
- Media posting slot
- Lockable lid for the insert
- Integral lockable lid
- Emergency key release, 3 position or no lock
- Alike or random locks
- Base plate for secure fixing + quick release
- Stainless steel finish for the lid

SPECIFICATION

FL-460

- Width: 460mm
- Depth: 172mm
- Height: 100mm
- Weight moulded insert: 5kg
- Weight universal insert: 7kg

FL-490

- Width: 490mm
- Depth: 172mm
- Height: 109mm

IDEAL FOR

- Convenience Stores
- Financial Institutions
- Hypermarkets
- Petrol Forecourts
- Supermarkets

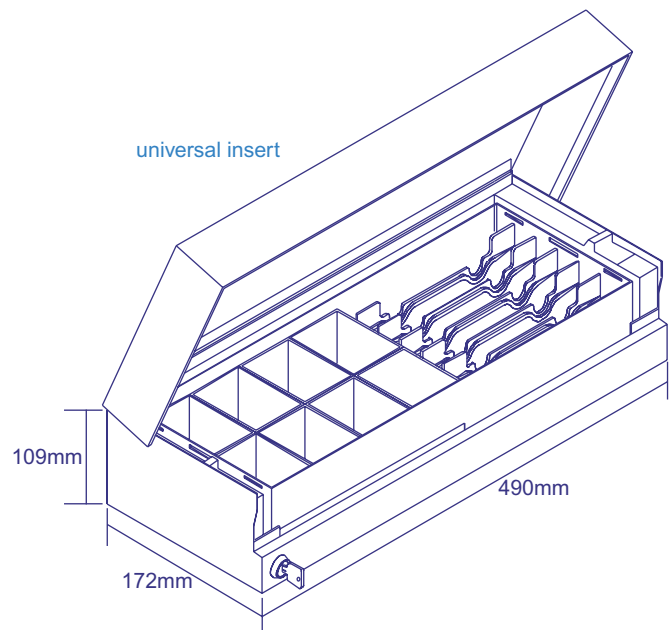
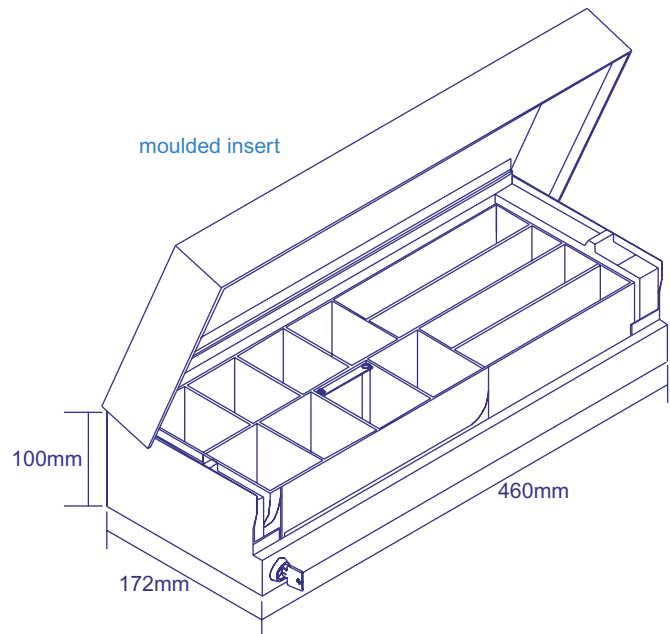

UK/CASH-FLIP/0803

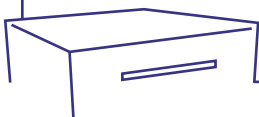

Specification may be subject to change without notification